

Gulliver 1500 - Rack Sliding Gate Operator

Rack sliding gates operator for industrial use These operators conceived for industrial and condominium use are suitable for gates from 1000 to 2000 kilograms. Their sturdiness are the components used that are guarantee for reliability over time. According to the articles they can be equipped with an electronic control board and an electromechanical brake. The release device with lever and key, in case the current is off, is easy to use. The adjustable mechanical clutch is a current product.

- Vertical gear
- Grease soaked gear motor
- Mechanical clutch
- Microswitches built-in limit switch
- Adjustable fixing plate
- Electrobrake



Description

Item 1500: Operator up to 1500 Kg. - 230 V mono-phase or 380 V three-phase

Item 1501: Operator up to 1500 Kg. with built-in electronic equipment - 230 V mono-phase or 380 V three-phase

Item 2000: Operator up to 2000 Kg. - 380 V three-phase

Item 2001: Operator up to 2000 Kg. - with built-in electronic equipment - 380 V three-phase

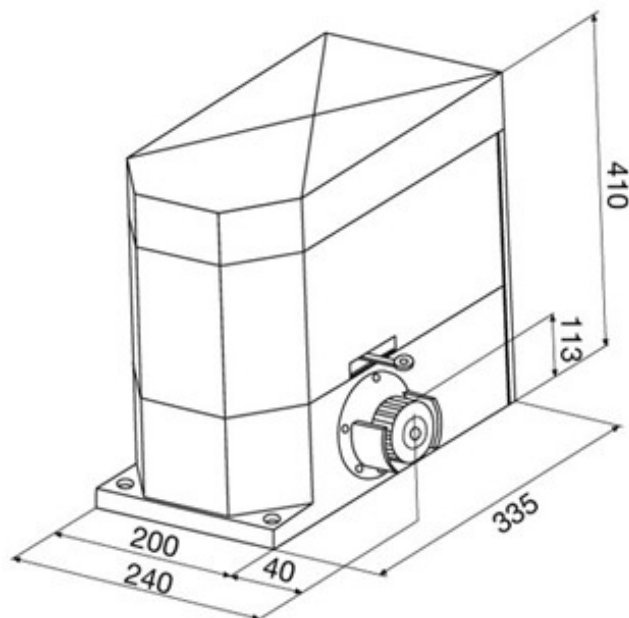

Model	1200	1500	2000
Hanging load Kg	1000	1500	2000
Volts	230	230/380	380
Absorbed Watt	650	850/1200	1800
Hz	50/60	50/60	50/60
Speed m/min	10	10	10
Thrust Max N	1570	800/1050	1450
I.L./h*	80%	80%	80%
Weight with packing	26 Kg	27 Kg	27 Kg

*I.L./h= Work Intermittence/Hour 220V - room temperature 20°C